

**voran**<sup>®</sup>

machinery

# Basket press 60K 100K



# Pressing fruit...

## The best from the basket

- High yield
- Smooth-running stainless steel eccentric closure for pivoting round basket
- All parts coming into contact with fruit are produced from stainless steel, wood or plastic
- Simple operation
- Easy cleaning
- Maintenance-free hydraulic pump without suction valve or collar
- Automatic 380-bar overpressure valve (for 100K) and 320 bar (for 60K)
- Oil-free pressing area due hydraulic system located beneath the press
- Low-maintenance technology

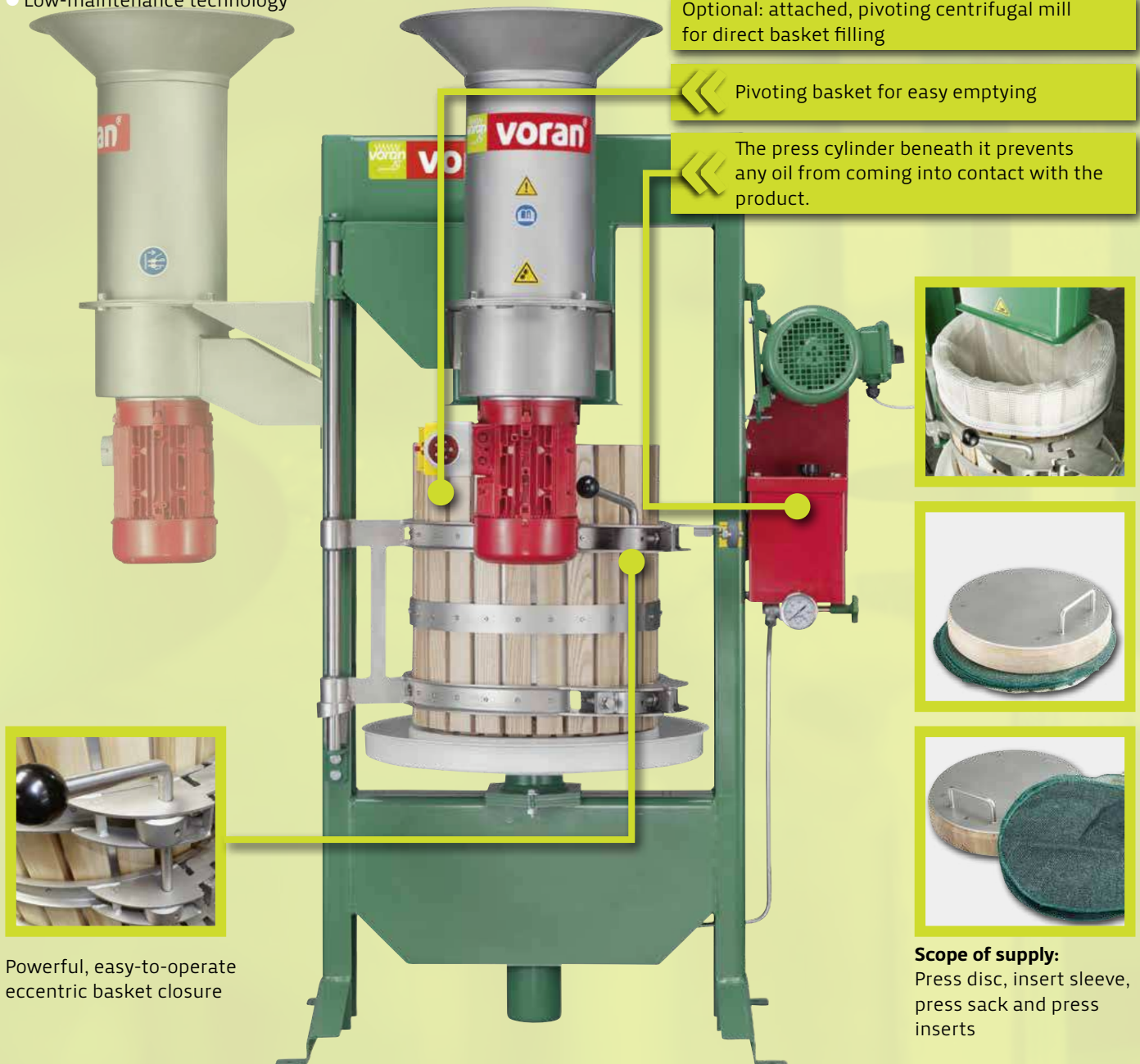
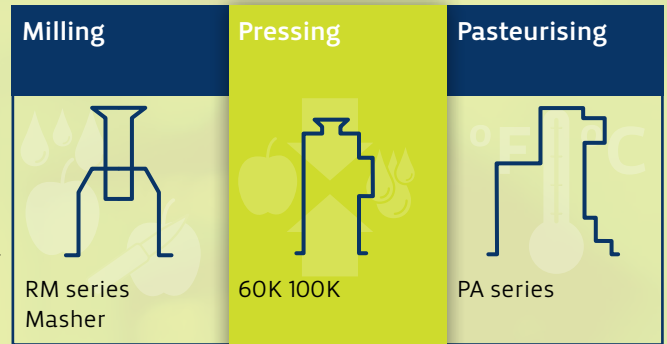

# ...and processing it further

## 60K

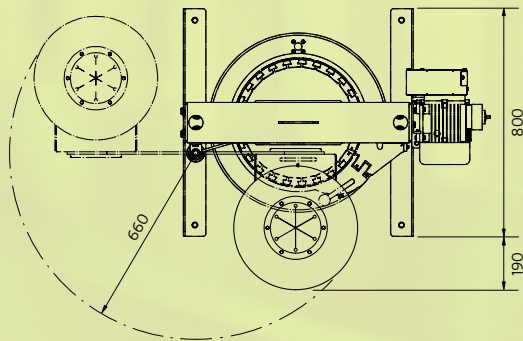

## 100K

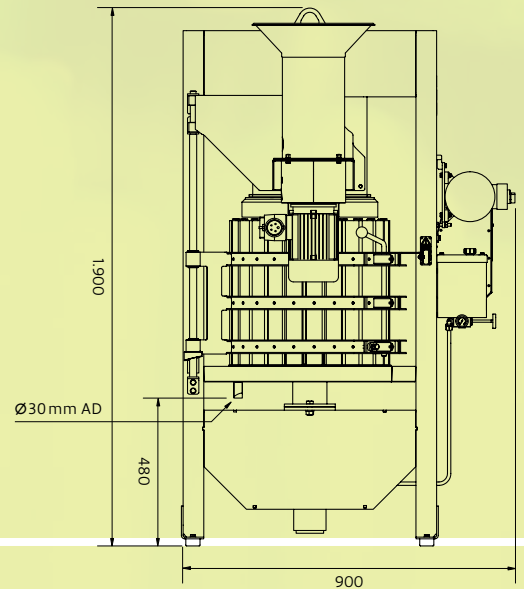
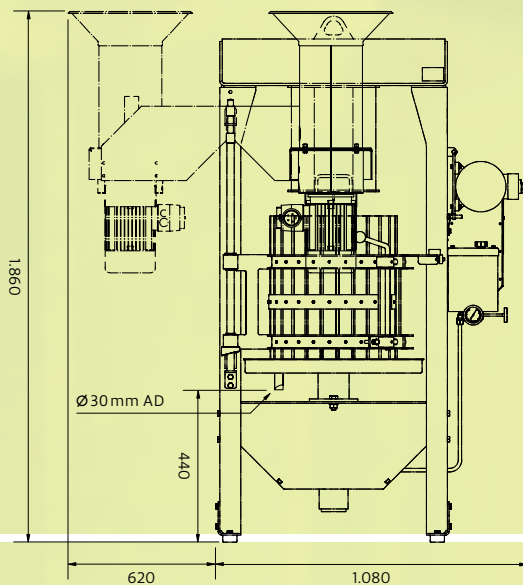
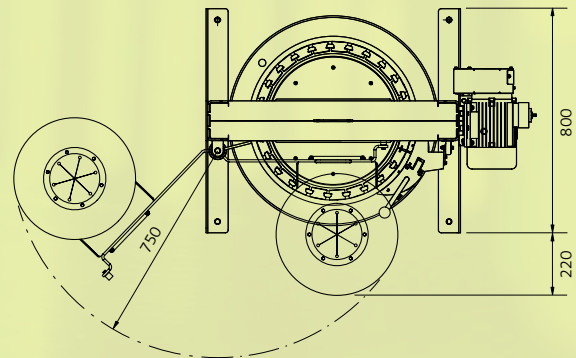

Model	60K (RM1,5)	100K (RM1,5)
Rated throughput in kg/h	180	300
Motor power in kW (mill)	1.1	1.5
Press force in kN	150	240
Electrical connection*	400V/50Hz (three-phase)	400V/50Hz (three-phase)
Plug	CEE 16 A	CEE 16 A
Length/width/height dimensions in mm (RM1,5)	800(990)/1,080(1,700)/1,840(1,860)	800(1,020)/900/1,850(1,900)
Weight in kg (mill)	264(28)	340(28)
Diameter of the inserts in cm	38	46
Number of cloths	3	3
Design	Powder-coated steel	Powder-coated steel
Scope of supply (applies for both presses)	3 press inserts, 3 insert sleeves, press sack, press disc	

\* Other mains voltages and designs on request



# voran.at

voran business lines

machines

machine construction

plant construction

facades

How to find us



**voran** Maschinen GmbH  
 Sales  
 Linzer Strasse 30  
 A 4650 Edt bei Lambach  
 T +43(0)72 49 / 444-0  
 F +43(0)72 49 / 444-888  
 office@voran.at  
 www.voran.at

**Production**  
 Inn 7  
 A 4632 Pichl bei Wels

**Service hotline**  
 Monday - Friday, 7 a.m. - 8 p.m.  
 Saturday, 7 a.m. - 6 p.m.  
 T +43(0)72 49 / 444-200