

**voran**<sup>®</sup>

machinery

# Fruit processing M500 line

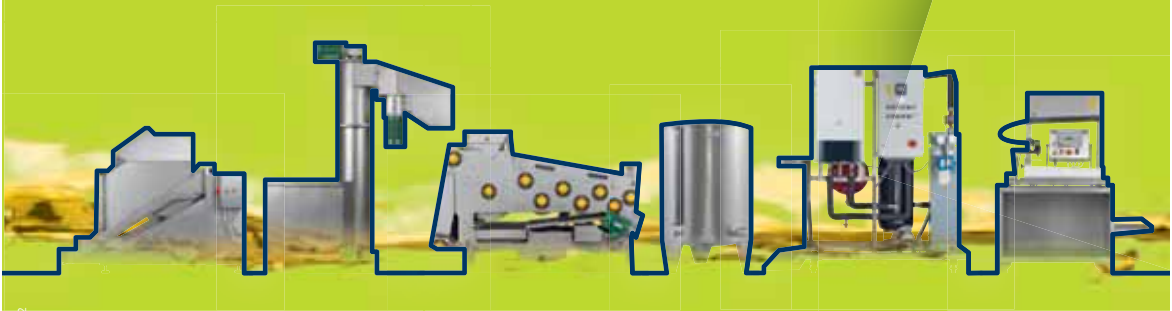

Fruit processing M500 line 2/12



Our solutions today set the standards for tomorrow.

# Provided by nature.

Emptying



Washing & mashing



Pressing



Filtering & settling



Pasteurisation



Filling



# Optimised by voran®.

## Filling

- integrated buffer with overflow protection
- takes 3, 5, 10 or 20 litre bags
- pre-programmed filling weight



## Pasteurisation

- fully-automatic operation
- filling not started until pasteurisation temperature has been reached
- plate-type heat exchanger suitable for juice



## Filtering & settling

- screens can be cleaned during processing (not shown)
- drain for clear and residue (tanks)
- optimum stability



## Pressing

- continuous operation
- high yield
- minimum space requirements



## Washing & mashing

- controlled automatically by press
- adjustable mash quality
- space-saving, flexible construction



## Emptying

- controlled feed from bulk bins
- high stability
- easy operation



# Implemented together.

## **voran® – Our solutions today set the standards for tomorrow.**

The modular configuration of the voran® M500 fruit processing line is a future-safe solution for producing and packaging high quality, natural, tasty, long-life products.

As the industry leader in commercial fruit processing, voran® has brought together the advantages of modular technology based on decades of experience, continuous development and consideration of market needs to bring you a customer-oriented, optimised overall concept.

Our industry-specific knowledge on production processes, quality factors, hygiene specifications for raw materials and operation of the plant contribute to the unrivalled quality of the final product as much as our high standards regarding production technology and mechanical engineering.

Our innovative overall solutions are geared towards the very highest level of technology, modular design and exceptional cost effectiveness for our customers.

With the voran® business model and our comprehensive support service you can concentrate on what matters most. Let voran® worry about the rest.



## **voran® – We supply the recipe as well as the kitchen.**

It is really important to us that we have an opportunity to talk to customers about the processes they need to implement so that we can ensure we design and deliver the perfect system.

From the installation plan to utilities required and the necessary connection points through to assisting in setting up the pressing room, we have a great deal of experience to input.

You can also benefit from the collective know-how gleaned from hundreds of reference projects that have already been implemented in a wide range of applications, capacities and countries.

Thanks to our comprehensive experience in storage and logistics we can guarantee rapid service, fast delivery of spare parts and straightforward, expert advice on processing, operation and any malfunctions that occur.



## **voran® – Where top quality is standard.**

Proven voran® quality is based primarily on the decades of experience as a specialist one-stop-shop for fruit processing systems. With hundreds of plug-and-play systems supplied, ongoing development to processing technology and a vast knowledgebase on quality indicators, voran® is your professional partner.

Maintaining hygiene when handling raw materials and operating the system are important factors. That is why voran® places great value on the ease of cleaning and compatibility for food contact of all components that come into contact with the product.

All modular components implemented by voran® ensure a long service life, high value retention and low maintenance costs. When our service team starts up a system for the first time, all function parameters are recorded in the handover check sheet to ensure reliable operation - so you can concentrate on your production.

The highest quality support and service is also standard at voran®. Detailed documentation including operating instructions and comprehensive functional description and troubleshooting/remedying instructions go without saying. Thanks to the use of standardised parts in manufacturing, we are also able to guarantee expert technical support and rapid availability of spares and wear parts. As part of our comprehensive service concept we offer pre-season preventive maintenance to ensure your system operates smoothly over the long-term.



**voran®**

**Stationary when you need it.  
Mobile when you want it to be.**

### **voran® M500 fruit processing line**

The voran® M500 fruit processing lines features machines that are perfectly matched to achieve a capacity of up to 500 litres per hour, depending on the fruit quality.

The M500 line has been implemented many times and is a modular system so that it can be perfectly adapted to your needs and specification to guarantee minimum manual work thanks to its high degree of automation.

The M500 mobil version offers the high capacity and all the advantages of the M500 line installed ready for operation on an aluminium-clad trailer.

### **voran® – Experience meets innovation.**

For decades voran® Maschinen GmbH has stood for quality, dynamic and professionalism in food and drink processing as part of the voran® Holding. As a financially stable medium-sized company we currently employ around 160 people in Pichl bei Wels – at the heart of the province of Upper Austria.

Always at the leading edge, we continue to develop proven systems as well as pioneer new ways, where experience and expertise count.

Transparency and a spirit of innovation motivate voran® to realise economically viable solutions featuring advanced technology in close cooperation with our customers.

**Visit us at [www.voran.at](http://www.voran.at) to learn more today about the standards for tomorrow.**

# WALC



## Space-saving and flexible

The washing and mashing systems are controlled completely automatically depending on the requirements of the belt press. They are designed with a rotating turret so that they can be installed flexibly without taking up too much space, and yet they are still easy to access for cleaning.

The raw material is cleaned in the integrated washing vessel, which is continuously fed with fresh water. The cleaned material is conveyed to the inline centrifugal mill by a vertical auger-type elevator. The quality of the mash can be adjusted if required using replaceable screens - no tools required.

## The voran® WALC highlights:

- up to 2,000 kg of fruit per hour
- automatic operation (controlled by belt press)
- interchangeable screens for adjustable mash quality - no tools required
- pip and stone protection tool
- rotating turret for space-saving installation and easy cleaning
- auger elevator features soft-start
- service-friendly design - e.g. split bearing on auger shaft
- integrated floor drain
- processes wide range of fruit and vegetables
- stainless steel construction

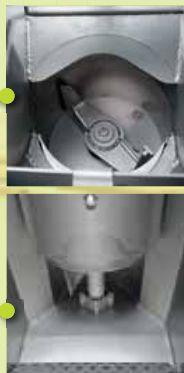



# EBP 500



## Continuous high yield

Optimum juice quality and yield are guaranteed thanks to the variable speed and pressure control for the EBP 500 belt press. The press is operated completely automatically and continuously.

The rate at which mash is fed to the press can be regulated individually for each product. The juice flows to the left or right virtually free of oxidation. The pomace is wiped away from the belt at the end of the pressing sequence. The efficient high-pressure belt cleaning system and optional brush system ensure optimum cleaning results.

## The voran® EBP 500 highlights:

- up to 700 kg of mash per hour
- high yield of up to 75 percent
- automatic continuous operation
- automatic belt regulation
- processes wide range of fruit, vegetables and herbs
- best juice quality
- low proportion of cloudy juice
- good accessibility - easy to clean
- minimum space requirements
- juice and waste water drain to left or right
- sealed roller bearings
- stainless steel construction

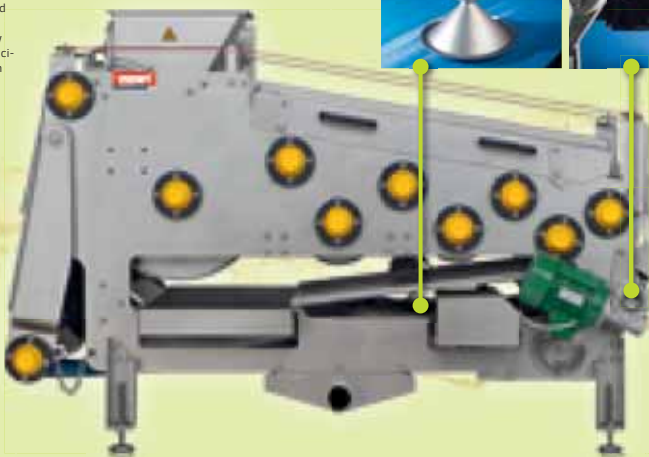

# PA 500-Gas



## Fully automatic and safe

The high quality control system of the PA 500 Gas pasteurisation system ensures that juice is fed to the filling unit only after it has reached the preset temperature. The whole system runs completely automatically - no operator required.

After the required temperature has been reached, the juice is fed from the buffer tank through the heat exchanger. If the temperature falls below the filling unit set point then the juice is fed back into the buffer tank. As soon as the juice has reached filling temperature the system switches over automatically to filling mode. The temperature of the juice can be regulated within +/- 0.4 degrees Celsius by modulating the power of the gas heater and the flow rate of the product. The system automatically switches over to standby mode if the filling unit buffer tank is full.



## The voran® PA 500-Gas highlights:

- up to 500 litres of juice per hour
- adjustable pasteurising and filling temperature
- fully automatic - no operator required
- precise temperature control
- reliable pasteurisation to protect product
- rapid availability thanks to short heating up time
- can be used to process small volumes
- heated buffer tank ensures continuity when stopping and starting
- system can be flushed using commercially available detergents
- plate-type heat exchanger suitable for juice
- product is conveyed carefully using stainless steel juice pump with neoprene impeller and dry running protection
- tight-welded stainless steel frame



# MBF 500



## Exact and compact

The MBF 500 fills bags almost free of bubbles and with no dripping thanks to its electronically-controlled filling valve. A weighing system guarantees precise metering of the filling amount.

The integrated buffer tank is fed directly from the pasteurising system. The filling system is able to remember two different filling weights that can be selected directly so that it is easy to change between different sizes of bag. After filling, the bag is closed manually and placed inside the box.

## The voran® MBF 500 highlights:

- up to 500 litres of juice per hour (with 10 litre bags)
- takes 3, 5, 10 or 20 litre bags
- minimal foam in bag thanks to pump-free filling
- exact filling weight
- weighing system (can be calibrated to Austrian standards)
- 2 filling weights can be stored and selected directly
- quick change between different volumes of bag
- 2 automatic counters that can be reset individually to zero
- integrated buffer tank with level indicator monitored by pasteurising system
- buffer tank can be drained completely empty
- efficient cleaning
- compact and space-saving construction
- stainless steel construction





The bulk bin tipper is designed to empty standard and special format large boxes of fruit at a controlled rate. Bulk boxes can be positioned on tipping system by hand truck or forklift. The whole tipping process takes around 20 seconds and can easily be stopped in any position. The complete system is built in stainless steel and features an integrated hydraulic power unit.



The collection basin is perfectly matched for connection to the EBP 500. The juice runs directly from the belt press through a removable, large surface 1 mm coarse screen to be collected in a 65 litre buffer tank. A stainless steel level switch automatically controls the impeller-type pump that is designed to carefully convey the product at flow rates of up to 1,800 litres per hour. The pump can also be switched on and off manually if the tank needs to be drained.

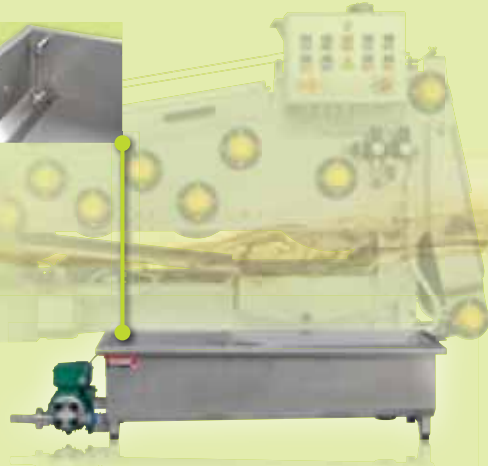

# Tanks



## Pipe-screen

The tanks are mainly used as buffer tanks with optional tanks available to allow cloudy product to settle prior to pasteurisation. Two connections at different heights for clear product and drain, an external measuring scale, three support legs for optimum stability and easy cleaning thanks to top surface finish quality of the stainless steel tank.

Efficient and cost-effective filtering with a mesh size of 0.25 mm. By implementing two gap screens in parallel it is possible to clean the screens without interrupting operation.

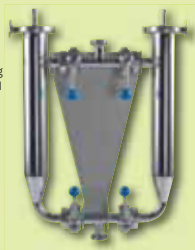

## Accessories

### Compressor

Kaeser Classic Mini

For belt tensioning and regulating EBP 500 and actuating filling valve on optional MBF 750.



### High pressure cleaner

Kärcher HD7/18C

For cleaning belt on the EBP 500 automatically.



# Options



## WAR 65

The WAR 65 combines power and extreme robustness with a space saving design and easy cleaning thanks to the rotating turret. The flow rate of mash is controlled depending on the requirements of the belt press. The quality of the mash can be adjusted to the type and quality of fruit being processed using replaceable screens - no tools required.

### The voran® WAR65 highlights:

- up to 6,000 kg of fruit per hour
- automatic operation (controlled by belt press)
- adjustable mash quality with replaceable screens - no tools required
- pip and stone protection tool
- thick plate construction - robust and reduces noise
- rotating turret for space-saving installation and easy cleaning
- auger elevator features soft-start
- service-friendly design
- integrated floor drain
- processes wide range of fruit and vegetables
- easily transportable



## EBP 500

Add-on supports can be fitted to the EBP 500 belt press so that it can easily be adjusted to the mash outlet height of the WAR 65. This means that standard size big boxes can be used for collecting pomace.





### Line filler 6-positions

The inline filling unit is designed for semi-automatic hot filling of fruit and vegetable juice from an integrated buffer tank into bottles between 0.25 and 2 litres. The filling height is individually adjustable and it is easy to switch bottle sizes without using any tools. A range of filling nozzle sizes are available for different bottle openings. Capacity is up to 600 litres per hour with 1 litre bottles.



### MBF750-R6

All features on the MBF 500 also apply to the MBF 750-R6. The main highlights are a capacity of up to 900 litres per hour with 10 litre bags and the optional 6-nozzle inline filling unit.



# Options



## Berries & Stone fruit

The combination of slanting conveyor and de-stoning unit is the right choice for the production of de-stoned mash from berries and stone fruit.

The high quality and homogenous mash with optimum aroma containment can be used directly for distilling or further processing with the belt press.

### SA

The slanting conveyor offers high flexibility in raw materials handling because it is ideal for all types of pomaceous fruit, stone fruit, berries and vegetables.

An integrated inspection screen is provided for hand selection. Rinsing takes place inside the wash tank while post cleaning is performed by a fresh water spray on the conveyor belt. The speed of the conveyor is infinitely variable.

The conveyor is available in three configurations:

- without centrifugal mill
- with centrifugal mill
- with pivoting centrifugal mill (shown)



## EP1000

The flow of raw material is regulated by a belt-driven central auger. The DN65 connection for the mash outlet leads directly to the mash pump or mash basin. Stones are ejected separately.

The main cover can be removed without tools so that the screen for straining berries can quickly and easily be replaced with a screen for processing cherries, plums, apricots and other types of stone fruit.

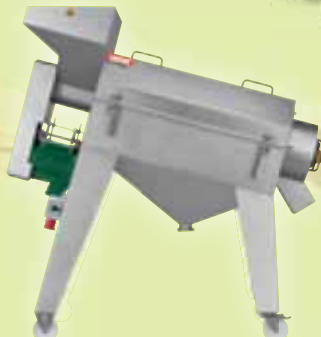

## Accessories

Mash pump: self-priming eccentric screw pump that can be connected directly to the EP 1000 or fitted with a mash funnel and feed auger.





# M500 mobil



## Mobile and complete

The M500 mobil system combines high capacity and all the advantages of the M500 on an aluminium-clad trailer. The M500 mobil is pre-installed ready for operation, fitted with central utility supply point and equipped to each customer's individual specifications.

## The voran® M500 mobil highlights:

- installed ready for operation
- central utility supply point (power, water)
- central control cabinet
- intuitive layout; robust construction
- proven standardised components
- individually designed
- effective intermediate and final cleaning
- high mobility with whole system on one trailer
- reach more customers
- rapid return on investment
- positive carbon balance thanks to shorter transport routes
- fruit is manipulated less often
- special trailer with pressing lines including EU certification for straightforward approval in Austria and Germany



# Installation plans

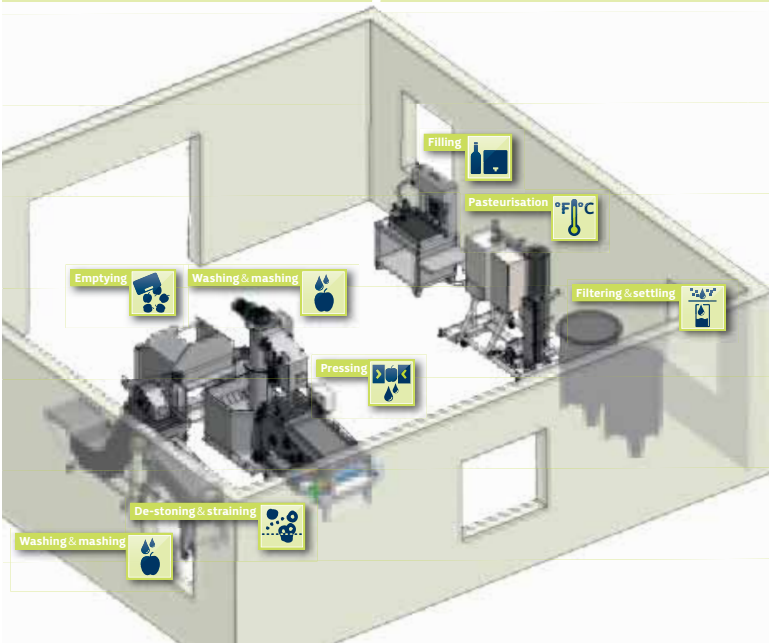

The installation layout shown here is one of the proven setups that has been implemented many times using the voran® M500 fruit processing line.

Of course the installation can be configured to perfectly match the layout of your site and your individual requirements.

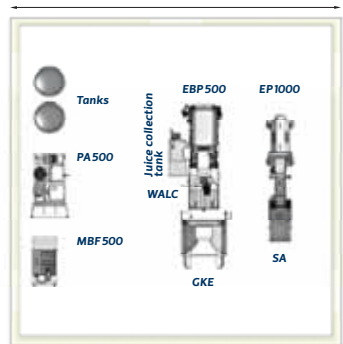

# Technical data

**GKE**

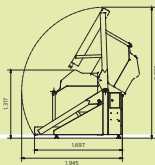

**WALC**

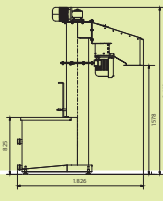

**EBP 500**

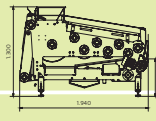

**Juice collection tank**

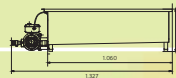

**PA 500-GAS**

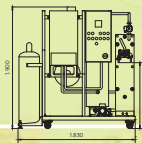

<b>Total weight in kg</b>	305	250	520	29	400
<b>Height/Width/Depth in mm</b>	1.317/1.697/1.466 (1.666)	2.419/1.826/ 616	1.300/1.940/1.161	290/1.327/ 508	1.900/1.830/1.100

**MBF 500**

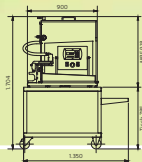

**Line filler 6-positions**

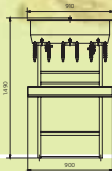

**WAR 65**

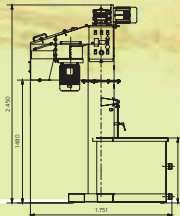

**SA**

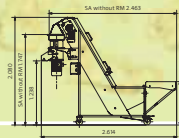

**EP1000**

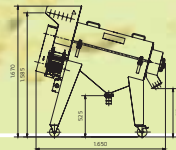

<b>Total weight in kg</b>	125	40	420	180	210
<b>Height/Width/Depth in mm</b>	1.704/1.350/ 700	1.490/910/420	2.450/1.751/ 873	2.080/2.614(2.463)/662	1.670/1.650/820

# voran.at

How to reach us

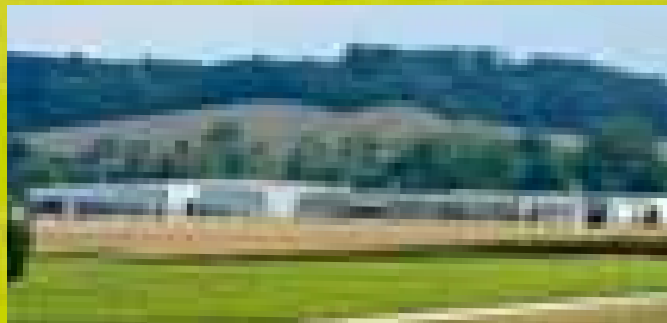
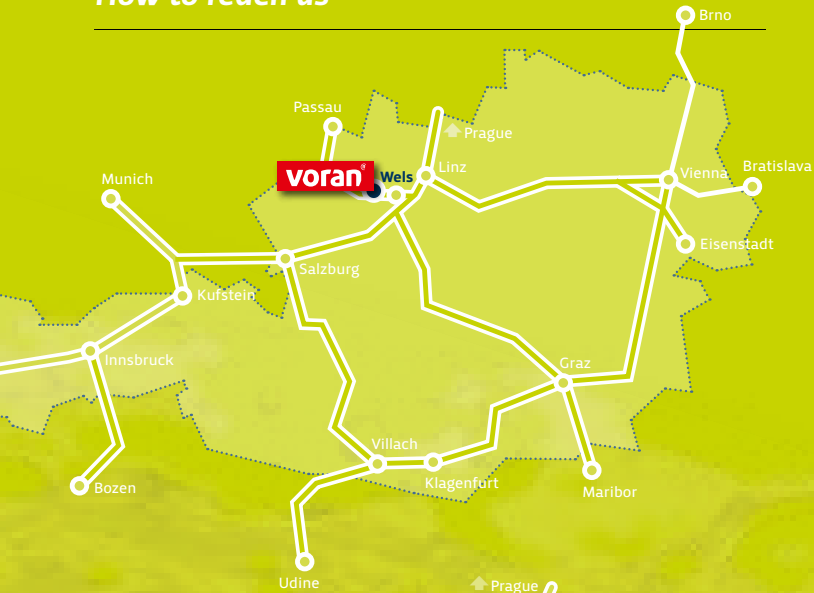

voran<sup>®</sup> GmbH business sectors

machinery

manufacturing

plant construction

facades

voran<sup>®</sup> Maschinen GmbH

Sales

Linzer Straße 30

A 4650 Edt bei Lambach

T +43 (0) 72 49 / 444-0

F +43 (0) 72 49 / 444-888

office@voran.at

www.voran.at

Production

Inn 7

A 4632 Pichl bei Wels