

### 1 1/2" Elima-Matic Food Processing

with Metallic Center Section

# E4

#### E4 Food Processing Pumps

- Stainless Steel

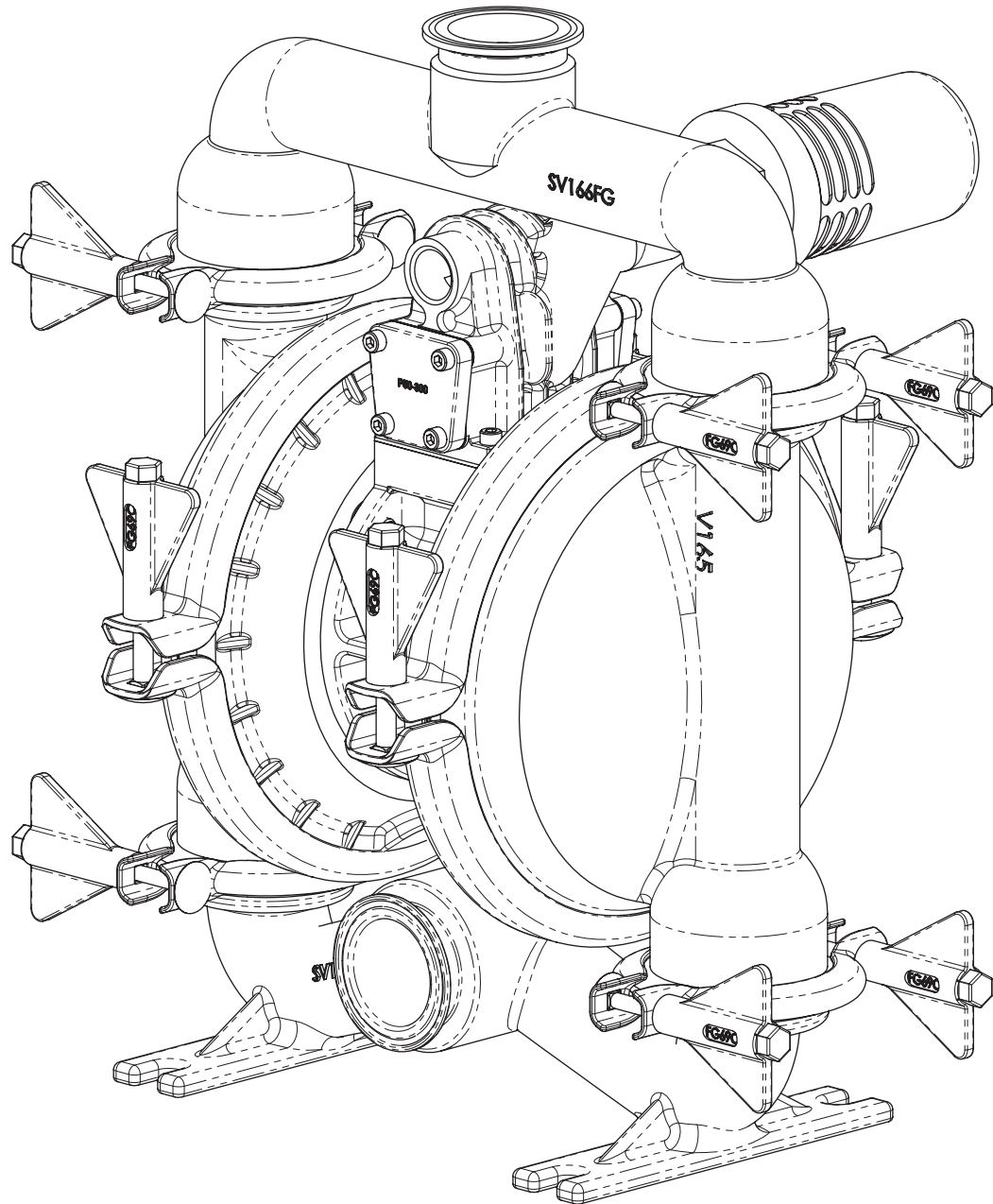

# Explanation of Pump Nomenclature

Your Serial #: (fill in from pump nameplate) \_\_\_\_\_

Your Model #: (fill in from pump nameplate)

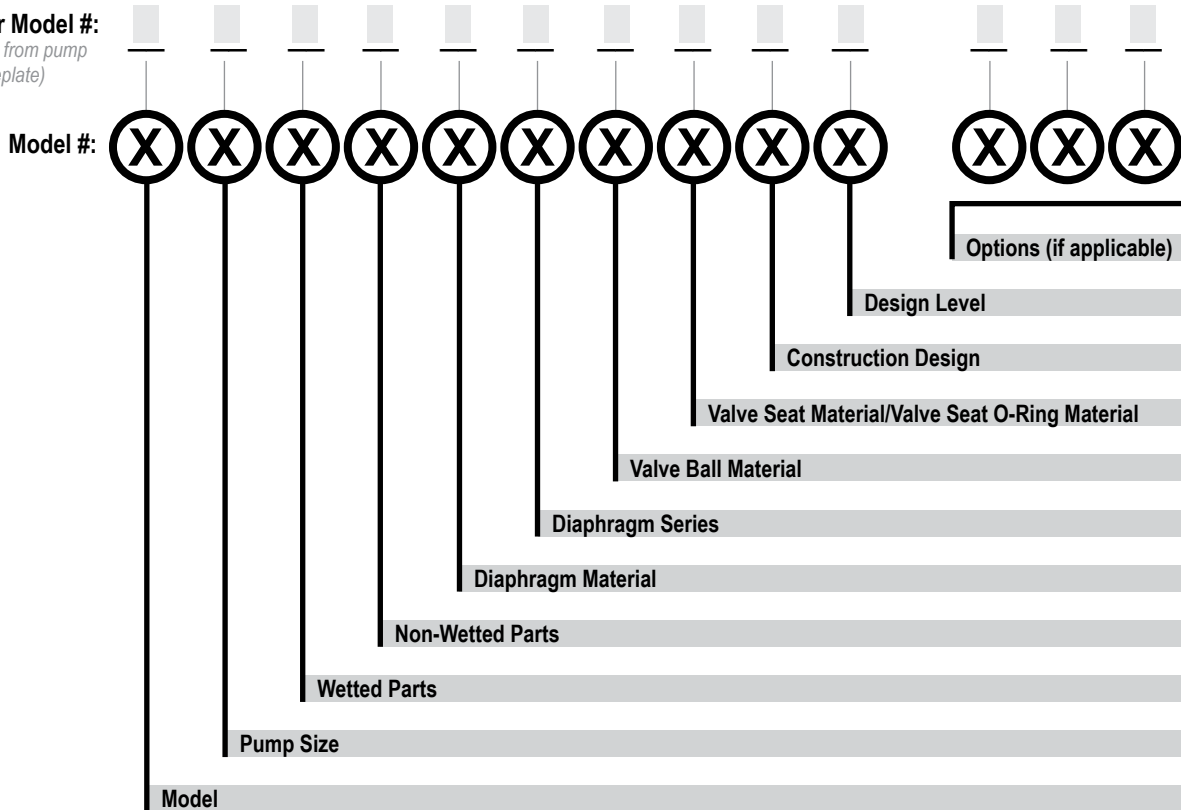

## Model

E Elima-Matic  
U Ultra-Matic  
V V-Series  
RE AirVantage

## Pump Size

6 1/4"  
8 3/8"  
5 1/2"  
7 3/4"  
1 1"  
4 1-1/4" or 1-1/2"  
2 2"  
3 3"

## Wetted Parts

A Aluminum  
C Cast Iron  
S Stainless Steel  
H Alloy C  
P Polypropylene  
K Kynar  
G Groundable Acetal  
B Aluminum (screen mount)

## Non-Wetted Parts

A Aluminum  
S Stainless Steel  
P Polypropylene  
G Groundable Acetal  
Z PTFE-coated Aluminum  
J Nickel-plated Aluminum  
C Cast Iron  
Q Epoxy-Coated Aluminum

## Diaphragm Material

1 Neoprene  
2 Nitrile (Nitrile)  
3 FKM (Fluorocarbon)  
4 EPDM  
5 PTFE  
6 Santoprene XL  
7 Hytrel  
9 Geolast  
Y FDA Santoprene

## Diaphragm Series

R Rugged  
D Dome  
X Thermo-Matic  
T Tef-Matic (2-piece)  
B Versa-Tuff (1-piece)  
F FUSION (one-piece integrated plate)

## Valve Ball Material Valve

1 Neoprene  
2 Nitrile  
3 (FKM) Fluorocarbon  
4 EPDM  
5 PTFE  
6 Santoprene XL  
7 Hytrel  
8 Polyurethane  
9 Geolast  
A Acetal  
S Stainless Steel  
Y FDA Santoprene

## Seat/Valve Seat O-Ring Material

1 Neoprene  
2 Nitrile  
3 (FKM) Fluorocarbon  
4 EPDM  
5 PTFE  
6 Santoprene XL  
7 Hytrel  
8 Polyurethane  
9 Geolast  
A Aluminum w/ PTFE O-Rings  
S Stainless Steel w/ PTFE O-Rings  
C Carbon Steel w/ PTFE O-Rings  
H Alloy C w/ PTFE O-Rings  
T PTFE Encapsulated Silicone O-Rings  
Y FDA Santoprene

## Construction Design

9 Bolted  
0 Clamped

## Design Level

A  
C

## Miscellaneous Options

B BSP Tapered Thread  
CP Center Port  
ATEX ATEX Compliant  
FP Food Processing  
SP Sanitary Pump  
HP High Pressure  
OE Original Elima-Matic  
F Flap Valve  
HD Horizontal Discharge  
3A 3-A Certified  
UL UL Listed  
OB Oil Bottle

\*More than one option may be specified for a particular pump model.

# Materials

Material Profile:	Operating Temperatures:	
	Max.	Min.
<b>CAUTION!</b> Operating temperature limitations are as follows:		
<b>Conductive Acetal:</b> Tough, impact resistant, ductile. Good abrasion resistance and low friction surface. Generally inert, with good chemical resistance except for strong acids and oxidizing agents.	190°F 88°C	-20°F -29°C
<b>EPDM:</b> Shows very good water and chemical resistance. Has poor resistance to oils and solvents, but is fair in ketones and alcohols.	280°F 138°C	-40°F -40°C
<b>FKM:</b> (Fluorocarbon) Shows good resistance to a wide range of oils and solvents; especially all aliphatic, aromatic and halogenated hydrocarbons, acids, animal and vegetable oils. Hot water or hot aqueous solutions (over 70°F) will attack FKM.	350°F 177°C	-40°F -40°C
<b>Hytrel®:</b> Good on acids, bases, amines and glycols at room temperatures only.	220°F 104°C	-20°F -29°C
<b>Neoprene:</b> All purpose. Resistance to vegetable oils. Generally not affected by moderate chemicals, fats, greases and many oils and solvents. Generally attacked by strong oxidizing acids, ketones, esters and nitro hydrocarbons and chlorinated aromatic hydrocarbons.	200°F 93°C	-10°F -23°C
<b>Nitrile:</b> General purpose, oil-resistant. Shows good solvent, oil, water and hydraulic fluid resistance. Should not be used with highly polar solvents like acetone and MEK, ozone, chlorinated hydrocarbons and nitro hydrocarbons.	190°F 88°C	-10°F -23°C
<b>Nylon:</b> 6/6 High strength and toughness over a wide temperature range. Moderate to good resistance to fuels, oils and chemicals.	180°F 82°C	32°F 0°C

<b>Polypropylene:</b> A thermoplastic polymer. Moderate tensile and flex strength. Resists strong acids and alkali. Attacked by chlorine, fuming nitric acid and other strong oxidizing agents.	180°F 82°C	32°F 0°C
<b>PVDF:</b> (Polyvinylidene Fluoride) A durable fluoroplastic with excellent chemical resistance. Excellent for UV applications. High tensile strength and impact resistance.	250°F 121°C	0°F -18°C
<b>Santoprene®:</b> Injection molded thermoplastic elastomer with no fabric layer. Long mechanical flex life. Excellent abrasion resistance.	275°F 135°C	-40°F -40°C
<b>UHMW PE:</b> A thermoplastic that is highly resistant to a broad range of chemicals. Exhibits outstanding abrasion and impact resistance, along with environmental stress-cracking resistance.	180°F 82°C	-35°F -37°C
<b>Urethane:</b> Shows good resistance to abrasives. Has poor resistance to most solvents and oils.	150°F 66°C	32°F 0°C
<b>Virgin PTFE:</b> (PFA/TFE) Chemically inert, virtually impervious. Very few chemicals are known to chemically react with PTFE; molten alkali metals, turbulent liquid or gaseous fluorine and a few fluoro-chemicals such as chlorine trifluoride or oxygen difluoride which readily liberate free fluorine at elevated temperatures.	220°F 104°C	-35°F -37°C
<i>Maximum and Minimum Temperatures are the limits for which these materials can be operated. Temperatures coupled with pressure affect the longevity of diaphragm pump components. Maximum life should not be expected at the extreme limits of the temperature ranges.</i>		
<b>Metals:</b>		
<b>Alloy C:</b> Equal to ASTM494 CW-12M-1 specification for nickel and nickel alloy.		
<b>Stainless Steel:</b> Equal to or exceeding ASTM specification A743 CF-8M for corrosion resistant iron chromium, iron chromium nickel and nickel based alloy castings for general applications. Commonly referred to as 316 Stainless Steel in the pump industry.		

For specific applications, always consult the Chemical Resistance Chart.

**Note:** This document is a high level guide. Please be aware that not all model and or material combinations are possible for all sizes. Please consult factory or your distributor for specific details.

## AFTERMARKET PARTS

### RIGHT PART, RIGHT NOW

**Pumper Parts** is your single source for parts that fit Air-Operated Double Diaphragm (AODD) pumps

- Wilden®
- ARO®
- Yamada®

**Designed to perform equal to or greater than original equipment manufacture.**



Phone: (419) 526-7296  
 info@pumperparts.com  
 www.pumperparts.com

Pumper Parts and its products are not affiliated with any of the original equipment manufacturers referenced herein. All original equipment manufacturers' names, colors, pictures, descriptions and part numbers are used for identification purposes only. Pumper Parts® is a registered trade name of IDEX Corporation. All other trademarks, registered trademarks and product names are the property of their respective owners. Yamada® is a registered trademark of Yamada Corporation. ARO® is a registered trade name of Ingersoll-Rand Company. Wilden® is a registered trade name of Wilden Pump and Engineering Company, a Dover Resources Company.

# Performance

## E4 1 1/2" Bolted Food Processing Pump ELASTOMERIC AND TPE FITTED

### Flow Rate

Adjustable to . . . . . 0-71 gpm (268 lpm)

### Port Size

Suction . . . . . 2" Tri-Clamp

Discharge . . . . . 2" Tri-Clamp

**Air Inlet** . . . . . 1/2" NPT

**Air Exhaust** . . . . . 3/4" NPT

### Suction Lift

Dry . . . . . 15' (4.57 m)

Wet . . . . . 25' (7.62 m)

### Max Solid Size (Diameter)

. . . . . 3/16" (4.76 mm)

**Max Noise Level** . . . . . 101 dB(A)

### Shipping Weights

Stainless Steel . . . . . 57 lbs (25.85 kg)

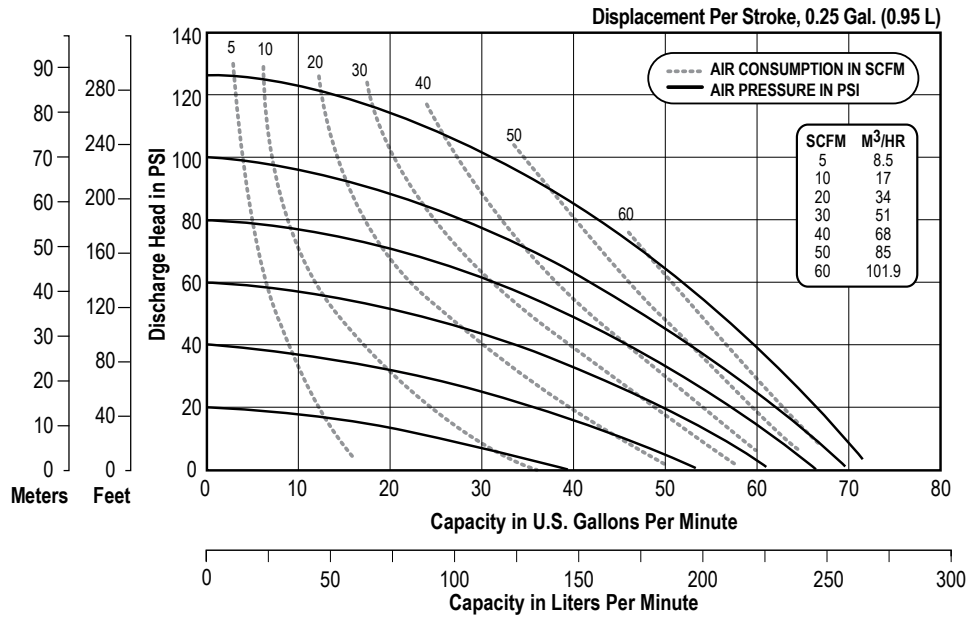

NOTE: Performance based on the following: elastomeric fitted pump, flooded suction, water at ambient conditions. The use of other materials and varying hydraulic conditions may result in deviations in excess of 5%.

## E4 1 1/2" Bolted Food Processing Pump PTFE FITTED

### Flow Rate

Adjustable to . . . . . 0-65 gpm (246 lpm)

### Port Size

Suction . . . . . 2" Tri-Clamp

Discharge . . . . . 2" Tri-Clamp

**Air Inlet** . . . . . 1/2" NPT

**Air Exhaust** . . . . . 3/4" NPT

### Suction Lift

Dry . . . . . 15' (4.57 m)

Wet . . . . . 25' (7.62 m)

### Max Solid Size (Diameter)

. . . . . 3/16" (4.76 mm)

**Max Noise Level** . . . . . 101 dB(A)

### Shipping Weights

Stainless Steel . . . . . 57 lbs (25.85 kg)

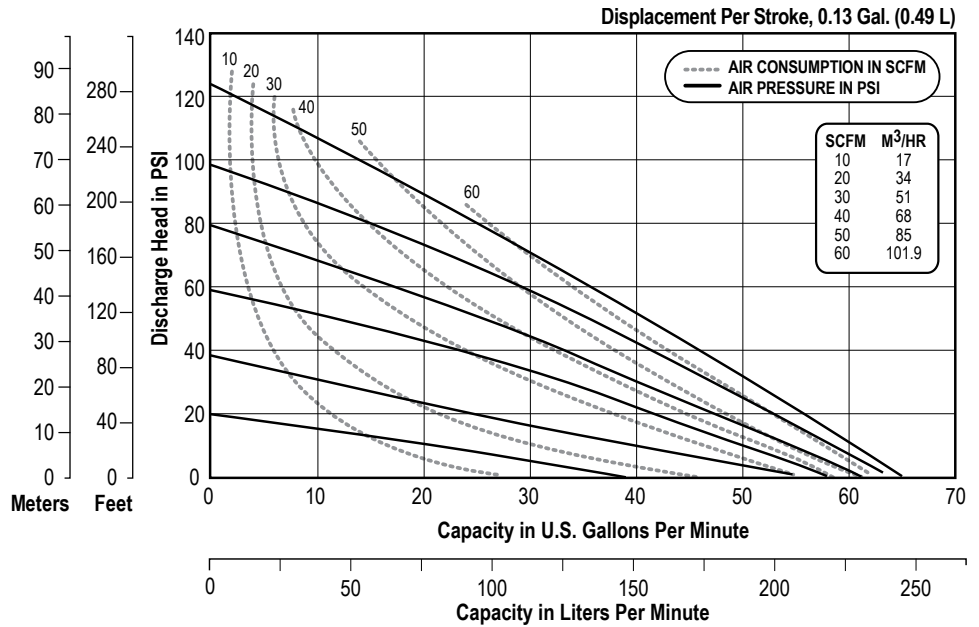

NOTE: Performance based on the following: elastomeric fitted pump, flooded suction, water at ambient conditions. The use of other materials and varying hydraulic conditions may result in deviations in excess of 5%.

# Dimensional Drawings

## E4 Food Processing

Dimensions in inches (metric dimensions in brackets)

The dimensions on this drawing are for reference only. A certified drawing can be requested if physical dimensions are needed.

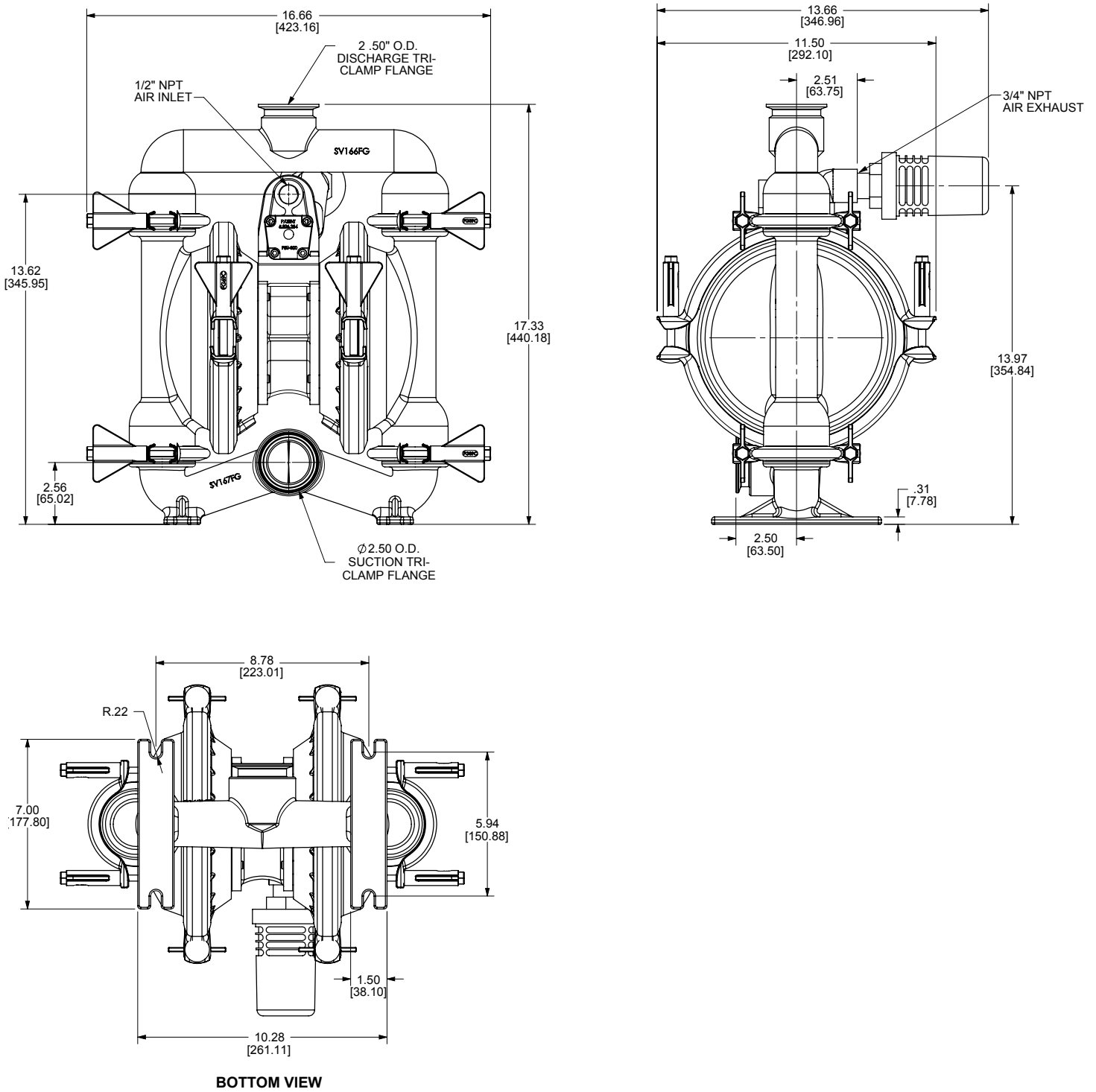

# Written Warranty

## 5 - YEAR Limited Product Warranty

Quality System ISO9001 Certified • Environmental Management Systems ISO14001 Certified

Versa-Matic warrants to the original end-use purchaser that no product sold by Versa-Matic that bears a Versa-Matic brand shall fail under normal use and service due to a defect in material or workmanship within five years from the date of shipment from Versa-Matic's factory.

~ See complete warranty at <http://www.versamatic.com/pdfs/VM%20Product%20Warranty.pdf> ~

### DECLARATION OF CONFORMITY

DECLARATION DE CONFORMITE • DECLARACION DE CONFORMIDAD • ERKLÄRUNG BEZÜGLICH EINHALTUNG DER VORSCHRIFTEN  
DICHIARAZIONE DI CONFORMITÀ • CONFORMITEITSVERKLARING • DEKLARATION OM ÖVERENSSTÄMMELSE  
EF-OVERENSSTEMMELSESERKLÆRING • VAATIMUSTENMUKAISUUSVAKUUTUS • SAMSVARSERKLÄRING  
DECLARAÇÃO DE CONFORMIDADE

#### MANUFACTURED BY:

FABRIQUE PAR:  
FABRICADA POR:  
HERGESTELLT VON:  
FABBRICATO DA:  
VERVAARDIGD DOOR:  
TILLVERKAD AV:  
FABRIKANT:  
VALMISTAJA:  
PRODUSENT:  
FABRICANTE:

VERSA-MATIC®  
Warren Rupp, Inc.  
A Unit of IDEX Corporation  
800 North Main Street  
P.O. Box 1568  
Mansfield, OH 44901-1568 USA  
Tel: 419-526-7296  
Fax: 419-526-7289



#### PUMP MODEL SERIES: E SERIES, V SERIES, VT SERIES, VSMA3, SPA15, RE SERIES AND U2 SERIES

##### This product complies with the following European Community Directives:

Ce produit est conforme aux directives de la Communauté européenne suivantes:

Este producto cumple con las siguientes Directrices de la Comunidad Europea:

Dieses produkt erfüllt die folgenden Vorschriften der Europäischen Gemeinschaft:

Questo prodotto è conforme alle seguenti direttive CEE:

Dir produkt voldoet aan de volgende EG-richtlijnen:

Denna produkt överensstämmer med följande EU direktiv:

Versa-Matic, Inc., erklærer herved som fabrikant, at ovennævnte produkt er i overensstemmelse med bestemmelserne i Direktive:

Tämä tuote täyttää seuraavien EC Direktiivien vaatimukset:

Dette produkt oppfyller kravene til følgende EC Direktiver:

Este produto está de acordo com as seguintes Directivas comunitárias:

**2006/42/EC**  
on Machinery, according  
to Annex VIII

##### This product has used the following harmonized standards to verify conformance:

Ce matériel est fabriqué selon les normes harmonisées suivantes, afin d' en garantir la conformité:

Este producto cumple con las siguientes directrices de la comunidad europea:

Dieses produkt ist nach folgenden harmonisierten standards gefertigt worden, die übereinstimmung wird bestätigt:

Questo prodotto ha utilizzato i seguenti standards per verificare la conformità:

De volgende geharmoniseerde normen werden gehanteerd om de conformiteit van dit produkt te garanderen:

För denna produkt har följande harmoniserande standarder använts för att bekräfta överensstämmelse:

Harmoniserede standarder, der er benyttet:

Tässä tuotteessa on sovellettu seuraavia yhdenmukaistettuja standardeja:

Dette produkt er produsert i overensstemmelse med følgende harmoniserte standarder:

Este produto utilizou os seguintes padrões harmonizados para verificar conformidade:

**EN809:1998+**  
**A1:2009**

#### AUTHORIZED/APPROVED BY:

Approuve par:  
Aprobado por:  
Genehmigt von:  
approvato da:  
Goedgekeurd door:  
Underskrift:  
Valtuutettuna:  
Bemyndiget av:  
Autorizado Por:

  
Dave Roseberry  
Engineering Manager

DATE: August 10, 2011

FECHA:  
DATUM:  
DATA:  
DATO:  
PÄIVÄYS:



VMQR 044FM

04/19/2012 REV 07



# Declaration of Conformity

**Manufacturer:**

**Warren Rupp, Inc.®, 800 N. Main Street, P.O. Box 1568,  
Mansfield, Ohio, 44901-1568 USA**

certifies that Elima-Matic® Air-Operated Double Diaphragm  
Food Processing and Sanitary Pump Models comply with the European  
Community Regulation 1935/2004/EC for Food Contact Materials.

E4SJ5T5S0-FP

E4SJYXY0-FP

E4SJ7X770-FP

E1SPYX5S9C-FP

E1SP7X759C-FP

E1SP5T559C-FP

E5SP5T5S9C-FP

E5SPYXY59C-FP

E5SP7X7S9C-FP

E1SJ5T559C-FP-ATEX

E1SJ7X759C-FP-ATEX

E1SJYX559C-FP-ATEX

E2SJ5T5S0C-FP-ATEX

E2SJ7X770C-FP-ATEX

E2SJ7D770C-FP-ATEX

E2SJYXY0C-FP-ATEX

E2SSYXY0C-FP-ATEX

E2SS7X770C-FP-ATEX

E3SJYXY0C-FP-ATEX

E3SJ5T550C-FP-ATEX

E3SJ5T5S0C-FP-ATEX

E3SSYXY0C-FP-ATEX

E3SS7X770C-FP-ATEX

E3SS5T550C-FP-ATEX

E4SJYXY40-SP

E4SJ7X750-SP

E2SJYXY40C-SP-ATEX

E2SJ7X750C-SP-ATEX

*David Roseberry*  
Signature of authorized person

David Roseberry  
Printed name of authorized person

Revision Level:

February 8, 2013  
Date of issue

Engineering Manager  
Title

\_\_\_\_\_  
Date of revision

**IDEX**  
CORPORATION

